

# Renovation of Crane Control System of Reach Stalker Ferrari 178h1 Using Avr Atmega2560

Lince Markis<sup>a,1</sup>, P.Susetyo Wardana<sup>b</sup>, Ardi Syawaldipa<sup>c,2,\*</sup>

<sup>a</sup> Department of Electricity Technology, University of 17 Agustus 1945 Surabaya, East Java, Indonesia

<sup>b</sup> Department of Electrical Engineering, State Electrical Polytechnic of Surabaya, East Java, Indonesia

<sup>c</sup> Department of Information Technology, Politeknik Negeri Padang, Padang, Indonesia

<sup>1</sup> [lince.markis@untag-sby.ac.id](mailto:lince.markis@untag-sby.ac.id), <sup>2</sup> [ardisyawaldipa@pnp.ac.id](mailto:ardisyawaldipa@pnp.ac.id)

\* corresponding author

## ARTICLE INFO

### Article history

Received May 16, 2022

Revised June 30, 2022

Accepted July 14, 2022

### Keywords

Crane

Hydraulic

Control

## ABSTRACT

Container rental service companies or container parking facilities providers need container transportation equipment such as Crane Reach Stalker to move and arrange containers. Several container services companies in Surabaya such as Citra Mandiri Sejati have a Crane Reach Stalker made by Ferrari Italy which experienced damage to the electrical control. After observing the control unit, the damage was in the hardware comparison system and the relay control used. Dealing with these problems, planning and improvement of the total control system were carried out using the ATMEGA2560 AVR microcontroller. However, the problem becomes complex and requires cooperation with Hydraulic control partners when the entire system must be resolved. From the renovation work on the Ferrari 178H1 Load Handling Crane system for a year, it was obtained that the Load Handling control input data in which it was a joystick and a 3 positions button with an output level of 0 and 9 volts. Hydraulic control uses a Solenoid Valve type 4/3 with 2 input control coils, and in overall system testing, the average length of time for the movement of the Piston Crane is 6 to 12 seconds. From the test results using a 40 tons container load, it was stated by the Crane driver that the time used to carry out Load Handling for the Hydraulic type and the Crane's age was suitable and appropriate.

This is an open access article under the [CC-BY-SA](https://creativecommons.org/licenses/by-sa/4.0/) license.



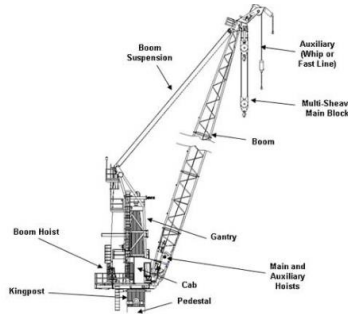
## 1. Introduction

This issue often occurs in the control crane Ferrari from Italy which was made in 1978. The control used by the crane Ferrari 178H1 is a mechanical control relay equipped with an analog comparator circuit using an IC opamp as a joystick input voltage detector and proximity sensor logic. To minimize the problem of damage to the control unit and simplify maintenance repairs for the Control Crane for container transporting the Ferrari 178H1 brand, a new control design was made using an AVR ATMEGA2560 microcontroller type.

## 2. Literature Review

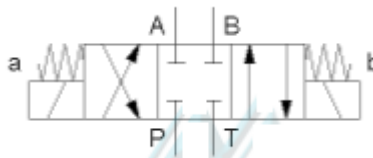
Crane control of this Ferrari 178H1 model is used to perform movements on the crane pulley and spreader (container holder) according to joystick input and spreader movement command buttons. The Movements for Load Handling (handling loads) include: Lifting (lifting the pulley), Extension

(extending the pulley forward), Slide shift (extending the spreader to the left and right), Spreading (shifting the spreader left and right), Rotation (turning the spreader to the left and right). spreader), Tilt (rotating the spreader forward) and Leveling (moving the spreader in an oblique direction of rotation left and right). Load Handling movement as shown in figure 1.



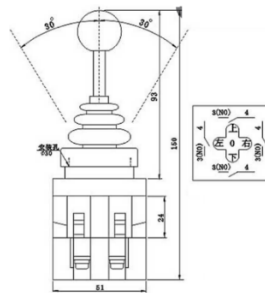
**Figure 1** Load Handling Crane Ferrari 178H1

Actuator crane Ferari 178H1 for Load Handling using Hydraulic control. Each hydraulic actuator is equipped with a type 4 input solenoid valve with a 2-way reverse movement, as shown in figure 2.

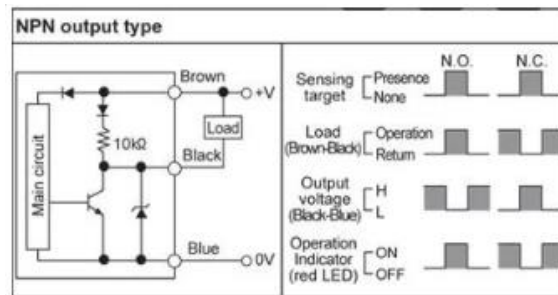


**Figure 2.** Model Solenoid Valve Crane Ferrari 178H1 type 4 Way 2 Electrical Control Input

The input system control and sensors for the Ferrari 178H1 include Joysticks for Lifting and Extension, DPDT buttons for spreader movements (side shift, spreading, rotation, tilt, and leveling). Proximity sensors at the 4 ends of the spreader to detect the locking position of the container.

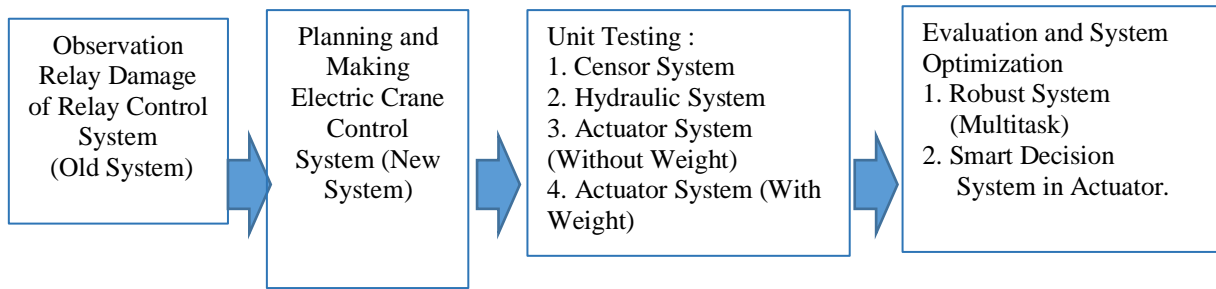


**Figure 3.** Joystick type 4NO



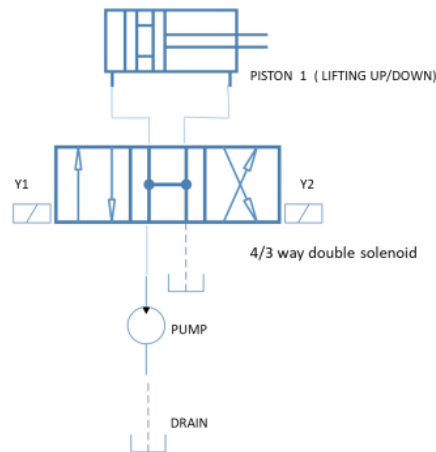
**Figure 4.** Proximity Sensor Type NPN Output

**3. Method**



**Figure 5.** Research Flow

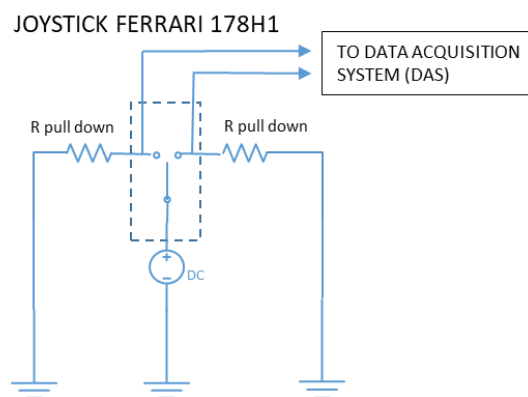
In the movement of the Ferrari 178H1 Crane to handle Load Handling, 4 pistons and a motor are used. The actuator which is capable of handling loads of up to 40 tons is driven by a hydraulic system which is controlled using an electric circuit. The hydraulic circuit is as shown in figure 6.



**Figure 6.** Hydraulic Series of Ferrari178H1 At Actuator of of PISTON 1 (Movement of Lifting Up/Down)

The movement of 4 pistons uses a solenoid valve type 4/3 hydraulic inlet and is controlled on coils Y1 and Y2. The coil can be active using a 24 Volt supply voltage, so that each coil is installed with a 24 Volt relay. In piston movement 1 (Lifting) it will move UP if coil Y1 gets a voltage input of 24 Vdc, while when coil Y2 is active (24 Vdc is active) it will move the Piston LIFT Down

For Joystick movement when Center position is 0 Volt (GND) in 4 movement positions (LIFT UP, LIFT DOWN, EXTENSION UP, EXTENSION DOWN). This can be seen from the joystick circuit in figure 7.



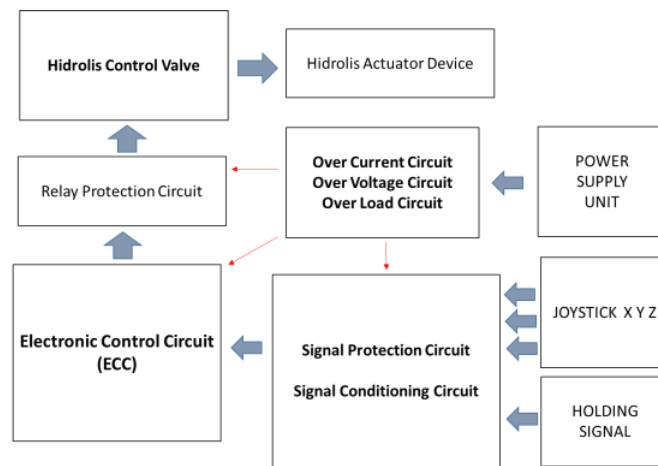
**Figure 7.** Joystick Schematic of Ferrari 178H1

Figure 7 is a schematic with the Vdc used is 9 volts with a Rpull up of 2 kΩ. Joystick position for Piston movement as shown in Table 1.

**Table 1.** Joystick Position and Piston Movement

| Piston Movement | Joystick Position      | Joystick Output (Volt) |
|-----------------|------------------------|------------------------|
| Center          | Center                 | 0                      |
| Lifting Up      | Direction to The Back  | 9                      |
| Lifting Down    | Direction to The Front | 9                      |
| Extension Up    | Direction to The Right | 9                      |
| Extension Down  | Direction to The Left  | 9                      |

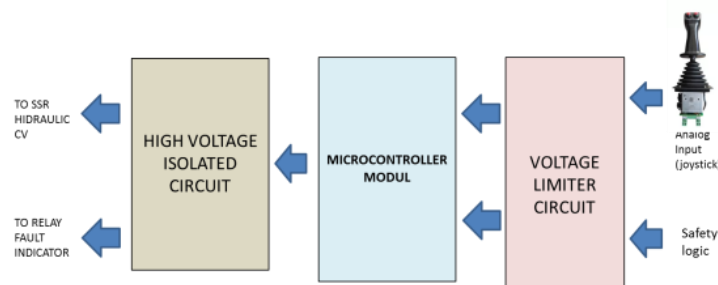
Control System "Load Handling" Crane / Reach Stacker Ferrari 178H1 uses an on - off control system with hysteresis. The Hysteresis function in the control system is used so that the joystick and spreader drive buttons can still be detected even though the voltage level of the 24 Volt battery main voltage has decreased.



**Figure 8.** Diagram Block of Thorough Control System “Load Handling” Crane Ferrari 178H1

### 3.1 Electronic Control Circuit (ECC) Modul

For the manufacture of ECC, a microcontroller type AVR module will be used to process lifting, extension, rotate and side shift data (from joystick input) and safety logic data (from hydraulic clogged sensors, over current, over voltage sensors) which are very important for securing systems and actuators. Hydraulic. Block Diagram of the ECC module as shown in figure 9.



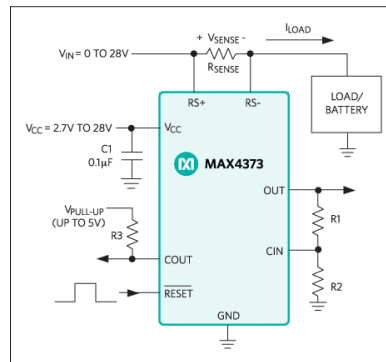
**Figure 9.** Diagram Block of ECC (Electronic Control Circuit)

Inside the ECC Unit there is a Voltage Limiter module at the ECC input position. The Voltage Limiter module is used to protect the microcontroller module from DC input that exceeds 5 Volts (because the Joystick output reaches 9 Volt dc). The unit voltage limiter is often called a voltage divider.

On the output side of the ECC there is a High Voltage Isolated Module which is used to assist the logic output of the microcontroller which is quite small (sink current is only 400 uA) but can drive a 24 Volt Relay. The IC is used for isolated voltage and voltage conversion is an NPN transistor output optocoupler type.

**3.2 Protection System**

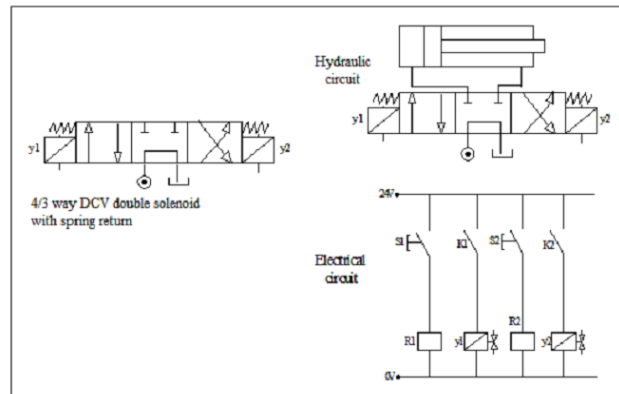
Several protection systems will be used in the manufacture of electronic control devices, such as Over Current, over Voltage in the power supply circuit. Several alarm signals from the Hydraulic system will also be included in the microcontroller programming algorithm as a safety system. The intended Over current circuit is as shown in figure 10.



**Figure 10.** Over Current Protection Circuit using MAX4373

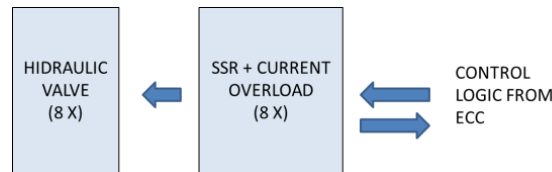
**3.3 Relay Based Hydraulics**

In the Hydraulic control panel that has been studied during field observations, the ferrari crane type 178H1 uses 4/3 double solenoids to drive the double acting actuator. Double type solenoid as shown in figure 11.



**Figure 11.** Model Double Solenoid Used in The Hydraulic System of Crane Ferrari 178H1

The double solenoid system uses 2 relays as shown in Figure 11. Both relays require input signals from S1 and S2 so that the relay becomes active and the relay contacts activate solenoids Y1 or Y2 which work alternately. When Y1 is active, the Hydraulic piston will move towards one side, while if Y2 is active it will move on the other side. There are 8 relays to perform all crane movements (Lift UP and DOWN, Extension and Retracted, Rotate Right and Left, Side Shift Right and Left) so that the block diagram is shown in Figure 12.



**Figure 12.** Hydraulic Valve and Relay Drive

Overload system to secure the solenoid valve from overload which is equipped with a breaker relay.

### 3.4 Data Acquisition

In planning for Electronic Control, the method of acquiring analog signal data from Joystick will also be used. Data acquisition using ADC (Analog to Digital Converter) contained in the AVR microcontroller which is used with a resolution of 10 bits.

After inputting data from the Joystick in the data acquisition, it will then be compared with reference data to obtain a logic value of 1 or 0. The advantage of using ADC and the process of comparing using a program is that the system becomes safer than the settings made by the operator when using the process of comparing with analog hardware circuits ( comparator IC with reference setting using multi tune).

From the program created, it will provide information on the form of an alarm from the indicator light for the results of the data comparison process. When the Joystick data input has been received, the indicator light will be turned on, and the results of the data comparison will also be presented in the form of an indicator light.

### 3.5 Power Supply Unit

The power supply source used is a Ferrari crane battery of 24 V, which will be divided into several output voltages, including 5 volts for ECC, 9 volts for joysticks and 24 volts for relays and sensors.

## 4. Result

The electric control system for the Ferrari 178H1 Crane uses the AVR ATmega 2560 as shown in figure 13.



**Figure 13.** Unit ECC Unit in Electric Control Panel of Crane Ferrari178H1

The overall results of the control system work and the output of the piston movement can be shown in the following Table 2.

**Table 2.** Test Result of Crane Movement Without Container Load

| Piston Movement                 | Movement Range | Joystick / Button       | Piston Movement Time (Mean / second) |
|---------------------------------|----------------|-------------------------|--------------------------------------|
| Lifting Up                      | Max + 60°      | Movement to The Back    | 12                                   |
| Lifting Down                    | Max - 60°      | Movement to The Front   | 12                                   |
| Extension - Up                  | Max +10 Mtr    | Movement to The Right   | 15                                   |
| Retraction - Down               | Max -10 Mtr    | Movement to The Left    | 10                                   |
| Rotation Right                  | Max +180°      | Switch Up Rotation      | 8                                    |
| Rotation Left                   | Max -180°      | Switch Down Rotation    | 8                                    |
| Spreader Ext. 20 Feet Container | Max 20 Feet    | Switch 20               | 6                                    |
| Spreader Ext. 40 Feet Container | Max 40 Feet    | Switch 40               | 8                                    |
| Shift Side Right                | Max +6 Feet    | Switch Shift Side Right | 4                                    |
| Shift Side Left                 | Max -6 Feet    | Switch Shift Side Left  | 4                                    |

**Figure 14.** Load Handling Test for Crane Ferrari 178H1 Using Container Load 40 Ton

## 5. Conclusion

The results of the Ferari 178H1 Load Handling Crane system indicated that the Load Handling control input data was a joystick and a 3 position button with an output level of 0 and 9 volts. Hydraulic control using Solenoid Valve type 4/3 with 2 input control coil. The system as a whole obtained the average length of time for the movement of the Piston Crane of 6 to 12 seconds through a 40 ton container load.

## References

- [1] M. Achmad Muhazir, "Perancangan Sistem Hidrolik Pada Pembangkit Listrik Tenaga Mikro Hidro," Karya, 2012.
- [2] A. Firdaus, T.Turmizi, A. Ariefin, "Perencanaan Perawatan Preventive dan Corrective pada Komponen Sistem Hidrolik Excavator Komatsu PC200-8," e-jurnal.pln.ac.id, 2017.
- [3] E.A.Syaefudin, "Rancang Bangun Excavator Sederhana Tipe Backhoe Berpenggerak Hidrolik," journal.unj.ac.id, 2014.
- [4] MD. Cahyono, NG Suryadharma, "Perencanaan Hidroliis Untuk Mesin Table Lift dengan Beban 1.5 Ton," jurnal Teknik Industri-univ45sby.ac.id, 2021.
- [5] B.Yan, X.Zhu, L.Wang, Y.Chang, "Integrated Scheduling of Rail-Mounted Gantry Cranes, Internal Trucks and Reach Stackers in Railway operation Area of Container Terminal," journals.sagepub.com, 2018.
- [6] A.Skaf, S.Lamrous, Z.Hammoudan, "Single Quay Crane and Multiple Yard Trucks Scheduling Problem with Integration of Reach-Stacker Crane at Port of Tripoli-Lebanon," ieeexplore.ieee.org, 2019.
- [7] Anonim, "Pengetahuan Hidrolik," Laboratorium Perancangan Mesin Institut Teknologi Bandung, 2002.
- [8] Hakim, Ridwan Isnan, "Perancangan Silinder Pompa dan Tangki Hidrolik pada Unit Passenger Stair PT United Tractors Pandu Engineering," Departemen Teknik Mesin UGM, Yogyakarta, 2014.

- 
- [9] L Rio Yusuf," Crane," Repository.stimart-amni.ac.id, 2019.
  - [10] Synergysolusi.com," Tower Crane, Hidraulik Crane, 2020.
  - [11] Wira.co.id," Pengertian, Jenis dan Fungsi Crane, 2021.
  - [12] Ciptahdropower.com," Pengertian Hidrolik Crane dan Cara Kerja Lengkap, September 2021.
  - [13] En.wikipedia.org," Crane (machine), July 2022.